



HYDRYER® TYPE C & E
Heat Regenerative
Dryers



GENERAL AIR
Making the world's air dryer

ISO 9001 CERTIFIED

C and E Hydryer[®] System

Introduction

The C and E series of regenerative dryers represents the latest in air drying technology. The C and E units are custom designed to meet process requirements and are fabricated per General Air design standards or customer specifications.

- **Open-Circuit Regeneration, Atmospheric Blower Purge with Dry Air Cooling (Hydryer Type C)**
- **Closed-Loop, No-Loss Regeneration (Hydryer Type E)**

Features/Benefits Common to C and E Dryers

Standard

- **Switching Valves** – 4-way non-lubricated or individual butterfly valves. Selection based on unit size and/or customer preference.
- **Removable Stainless Steel Desiccant Support Screen** – Provides air flow dispersion, retains desiccant and can be easily cleaned or replaced.
- **Pressure Relief Valves** – One valve per tower to protect the dryer from excessive pressure.
- **Pilot Air Filter** – Protects the dryer's pneumatic devices, minimizing dryer maintenance.
- **NEMA 4 Electrical Standards** – Allows the dryer to be located indoors or outdoors.
- **Control Transformer** – 460/3/60 to 120/1/60.
- **Solid-State Controls** – Extremely reliable, long-life components.
- **Remote Alarm Contact** – Provides capability to inform central control of an alarm condition.
- **Tower-On Stream Lights** – Assist in verifying the operation and mode.
- **Power-On Switch and Indicator Light** – Safety device to indicate the power supply is on.
- **High-Quality Industrial Paint** – Provides protection to prevent external corrosion.
- **Towers** – 150 PSIG design per ASME Section VIII, Div. 1, with fill and dump ports.
- **-40°F Pressure Dew Point** – Standard exit dew point specification.
- **Heater Overtemperature Protection** – Virtually eliminates heater burnout.

Optional

- **Dryer Inlet/Outlet Pressure and Temperature Gauges** – Used to verify operating parameters.
- **Color-Change Moisture Indicator** – Utilizes silica beads which are blue when dry and pink when wet.
- **High-Humidity Alarm** – Visual alarm occurs when dryer experiences high outlet dew point. Audible alarm also available.
- **Moisture Analyzer with Alarm** – Accurately monitors outlet dew point in critical applications. Includes adjustable alarm set point.
- **NEMA 4, Type Z Purge (Class I, Div. 2, Group C and D) electrical enclosure.**
- **Audible Alarm** – Alerts operators in the area that an alarm condition exists.
- **Stainless-Steel Instrument Air Tubing** – Designed for especially corrosive environments.
- **High-Quality Industrial Paint with Zinc Primer** – Provides surface protection for more corrosive environments.
- **Low Ambient Control Panel Strip Heater** – Allows dryer to be used in low temperature outdoor areas.
- **Disconnect Switch** – Provides electrical isolation, if required for maintenance.
- **Steam Heater** – Used where steam is available for lower operating costs.
- **Demand Drying** – Provides efficient operation at the lowest energy cost. See page 3 for details.

(Optional) Demand Drying Energy Management System For Type C and E Dryers

Dryers are sized for maximum design flow rate and maximum design moisture load (based on pressure and temperature). In other words, dryers are sized for “worst case” operating conditions. The dryer is rarely operated at this set of conditions. Operating the dryer on a fixed cycle, therefore, wastes energy since the actual moisture load is less than design.

The GAD Energy Management Systems are designed to enhance the overall operating efficiency of each type of dryer by consuming only as much energy as is necessary to maintain the required outlet dew point throughout the entire operating range of the dryers.

Operation

An air sample is continuously monitored from the desiccant bed of the on-stream (drying) tower. If the humidity set point has been reached by the end of the 4-hour drying cycle, tower switchover will occur. If not, the demand cycle controller will put the solid-state timer on hold. The timer stays on hold until the humidity reaches its set point. Then, the timer resumes operation, and tower switchover occurs. The timer now resumes another 4-hour drying cycle.

The GAD **Demand Drying** optional controller will enable you to get the full capacity from the desiccant bed during each and every cycle. It will also save considerable wear and tear on the switching valves since they may switch only one-quarter as often (based on a typical 25% dryer loading).

Features/Benefits

Lower Maintenance and Cost Savings:

- **Energy Conservation** – Extending the adsorption time provides the greatest energy savings, while heating/cooling termination provides additional savings.
- **Longer Desiccant Life** – Desiccant attrition is reduced as a result of fewer tower switchovers.
- **Extended Valve Life** – Valve wear and tear is reduced because the drying cycle is extended, causing fewer cycles.

Reliable Design and Quality

Construction:

- **Solid-State Control Board** – Provides dependable operation.
- **Humistat** – Provides an accurate measurement of relative humidity in the desiccant bed.
- **Sample Ports** – The sample ports are located near the outlet of each desiccant bed. There is additional desiccant below them to provide extra drying capacity for added reliability.
- **Sample Air Filter** – Protects the moisture probe to assure accurate readings.

Energy Savings From Demand Drying

Energy Savings Calculation

$$\% \text{ Loading} = \frac{\text{SCFM (actual)}}{\text{SCFM (design)}} \times \frac{T_F \text{ (actual)}}{T_F \text{ (design)}} \times \frac{P_F \text{ (actual)}}{P_F \text{ (design)}}$$

$$\% \text{ Savings} = 1 - \% \text{ Loading}$$

T_F = Temperature Factor

Temp (°F)	60	70	80	90	100	110	120
T_F	.3	.4	.55	.75	1.0	1.3	1.7

P_F = Pressure Factor

Pressure (PSIG)	60	70	80	90	100	110	120
P_F	1.55	1.35	1.2	1.1	1.0	.9	.85

The energy savings can be estimated using the above calculations. The “actual” factor represents the anticipated *average* flow. If flow is not continuous, the average should be estimated.

GAD Type C Hydryer

Open Circuit, Blower Purge Regeneration

Introduction

The GAD Hydryer **Type C** utilizes atmospheric air for reactivation and a percent of dry air for the cooling portion of reactivation. The **Type C** requires a minimum amount of equipment since no cooler or separator is needed. The reactivation air is vented to the atmosphere.

An ideal system for drying instrument or process air, the **Type C** Hydryer cuts maintenance costs, space requirements, and, most importantly, minimizes compressed air purge losses.

The standard design utilizes electric (or optional steam) heat regeneration offering a pressure dew point of -40°F or lower for air flows ranging from 1,250 SCFM to 10,000 SCFM. (Dryers designed for other conditions are available.)

The **Type C** is a dual-tower unit operated on an 8-hour NEMA cycle (4 hours drying and 4 hours regenerating) by two 4-way non-lubricated plug valves, interlocked for a positive flow diversion or by individual butterfly valves. Electrical enclosures are NEMA 4; the unit is designed for operation from a 460/3/60 power supply.

The simplified regeneration circuit consists of a regeneration gas blower equipped with an inlet-air filter/silencer and externally situated electric (or optional steam) heater.

Standard design utilizes a fully automatic controller, with the energy-saving automatic heating and cooling termination feature included.

The control circuit and instruments offer complete trouble-free, self-diagnosing automatic operation, utilizing pressure switches to verify proper cycling. A Cycle Failure Alarm provides notice of a disruption in operation. Safety interlocks protect the system in the event of a malfunction.

Principles of Operation

- **Adsorption (Drying)**
The wet air flows down through the desiccant for 4 hours, reducing the gas moisture content to an average -40°F pressure dew point or lower.
- **Regeneration (Heating)**
Atmospheric air flows through an externally situated electric (or optional steam) heater. This regeneration air enters the bottom of the dryer tower, driving off the adsorbed moisture as it passes through it in an upward direction. The liberated moisture is carried out of the bed and into the atmosphere.
- **Cooling**
After regeneration, the desiccant bed is cooled down by utilizing a percent of dry air. This minimizes temperature and dew point spikes at switchover and avoids preloading of the bed.

Standard Features/Benefits

- **Tower Pressure and Temperature Gauges** – Indicate individual tower pressures and temperatures.
- **Heater Overtemperature Control** – Solid-state temperature switches are factory set for trouble-free start-up.
- **Automatic Heating/Cooling Termination** – Saves energy during low demand periods.
- **Heater Overtemperature Alarm/Light** – Provides immediate notification of heater problems.
- **Heating/Cooling Status Light** – Provides visual indication of dryer status within the cycle.
- **Cycle Failure Alarm** – Occurs if dryer experiences a cyclic malfunction, via pressure switch.
- **Depressurization Silencer/Muffler** – Decreases noise level output.

Optional Features/Benefits

- **Insulation** – Minimizes heat losses and provides protection for personnel.
- **Non-Lubricated 4-Way Valves** – Lubrication-related maintenance is avoided. Dual-interlocked valves assure smooth switchover.
- **Blower Pressure Indicator** – Used to verify blower boost.
- **Heater Failure Alarm With Light** – Signals an electric heater fault condition.
- **Individual Butterfly Switching Valves**

Flow Diagram – Type C – Individual Butterfly and Check Switching Valves

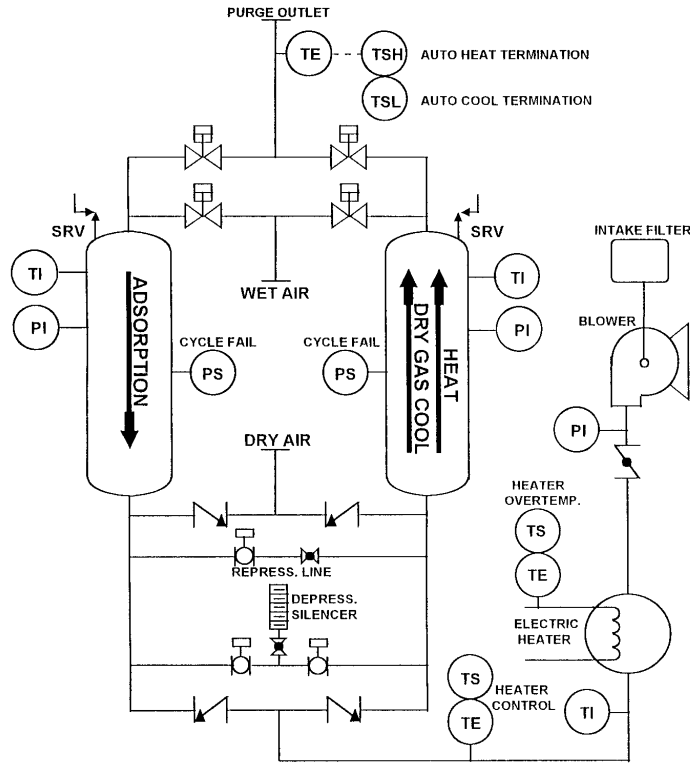

Flow Diagram – Type C – Non-Lubricated 4-Way Switching Valves

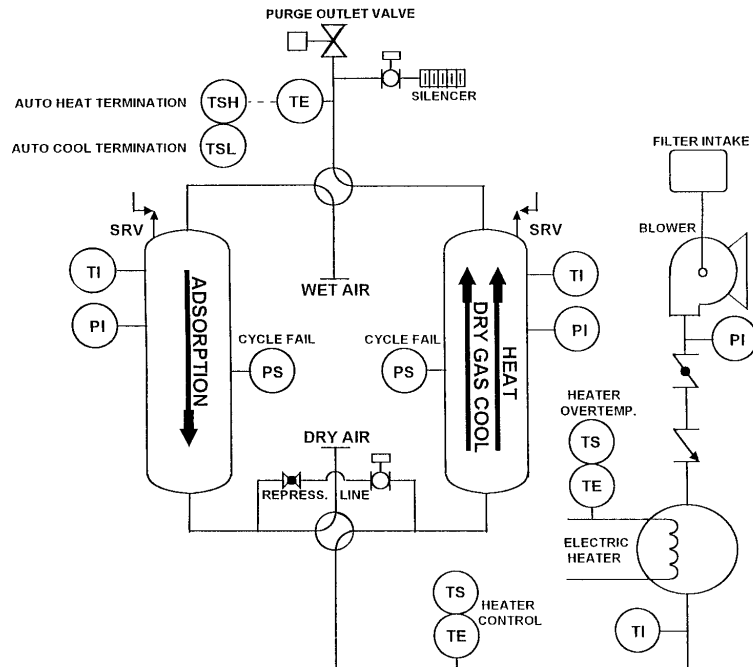

GAD Type E Hydryer

Closed Loop, No-Loss Regeneration

Introduction

The GAD Hydryer **Type E** utilizes a closed-loop reactivation, eliminating purge loss. It is ideal for drying compressed air, carbon dioxide, helium, nitrogen, hydrogen, natural gas, fuel gas, etc.

The standard design utilizes electric (or optional steam) heat regeneration, offering pressure dew points of -40°F or lower for gas flows ranging from 1,250 SCFM to 10,000 SCFM. (Dryers for other conditions are available.)

The **Type E** is a dual-tower unit operated on an 8-hour NEMA cycle by two 4-way non-lubricated valves, interlocked for positive flow diversion or by individual butterfly valves. Electrical enclosures are NEMA 4 rated for operation from a 460/3/60 power supply.

The regeneration circuit consists of a regeneration gas blower, external electric (or optional steam) heater, water-cooled cooler condenser and a liquid water separator.

The dryer regenerates at line pressure, eliminating bed disturbances due to pressure bleed and build up, and also provides lower operating costs.

Standard design utilizes a fully automatic controller, with the energy-saving automatic heating and cooling termination feature included.

When electric heating is the choice, the control panel combines a solid-state controller and high-temperature cut-off preventing electric heater burnout.

Principles of Operation

- **Adsorption (Drying)**
The wet air flows down through the desiccant for 4 hours (standard design), reducing the gas moisture content to -40°F pressure dew point.
- **Regeneration (Heating)**
Regeneration is accomplished by recirculating a captive volume of gas (air, nitrogen, natural gas, etc.) at line pressure. The regeneration heat is supplied by an externally situated electric (or optional steam) heater. The heated gas enters the top of the dryer tower, driving off the adsorbed moisture. The liberated moisture is carried out of the bed into the water-cooled cooler, where the water vapor is condensed, liquid water is separated, and the gas is drawn into the recirculation blower.
- **Cooling**
After regeneration, the desiccant bed is cooled down by recirculating the captive volume of gas with the heater turned off.

Standard Features/Benefits

- **Tower Pressure & Temperature Gauges** – Indicate individual tower pressures and temperatures.
- **Temperature Gauge on Heater Discharge.**
- **Heater Overtemperature Control.**
- **Heater Overtemperature Alarm/Light** – Provides immediate notification of heater problems.
- **Heating/Cooling Status Light** – Provides visual indication of dryer status within the cycle.
- **Automatic Heating/Cooling Termination** – Saves energy during low demand periods.
- **Safety Interlock** – Protects against cycling during upset conditions.

Optional Features/Benefits

- **Insulation** – Minimizes heat loss and provides protection for personnel.
- **Switching Valve Failure Alarm/Light** – Limit switch is used to verify valve switching.
- **Blower Pressure Indicator** – Used to verify blower boost.
- **Heater Failure Alarm With Light** – Signals an electric heater fault condition.
- **Cooler Failure/Separator – High-Level Alarm** – Protects the blower should the cooler or separator fail.
- **Oversize Piping** – Used when minimal pressure drop is required.

Flow Diagram – Type E – Non-Lubricated 4-Way Switching Valves

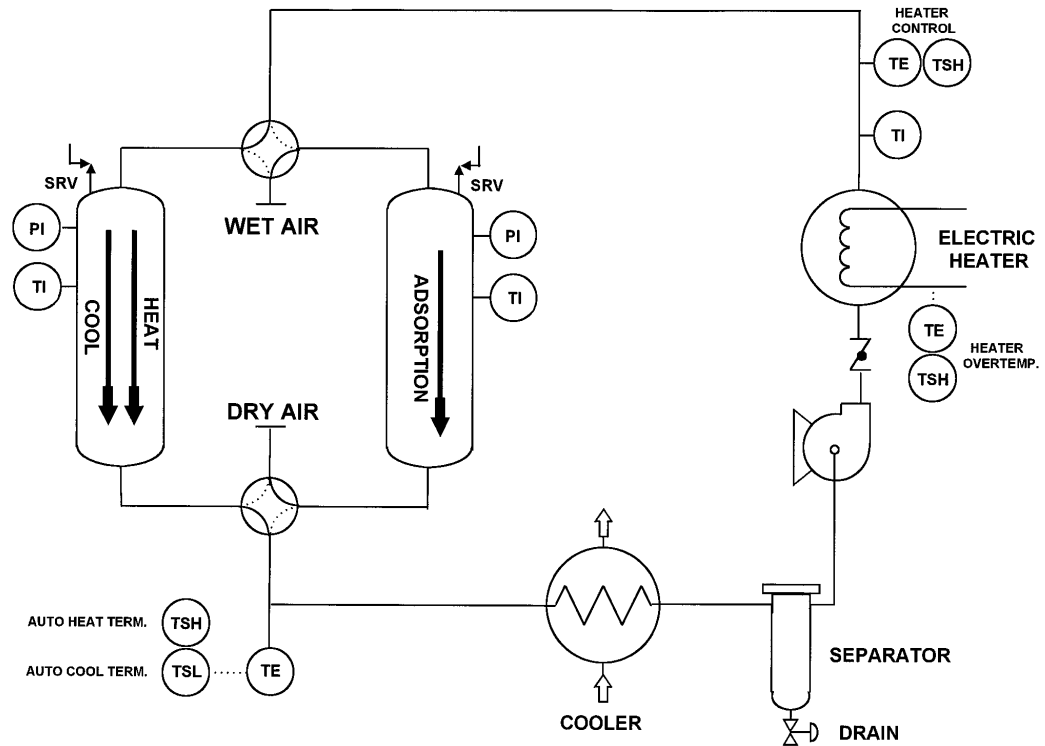

Flow Diagram – Type E – Individual Butterfly Switching Valves

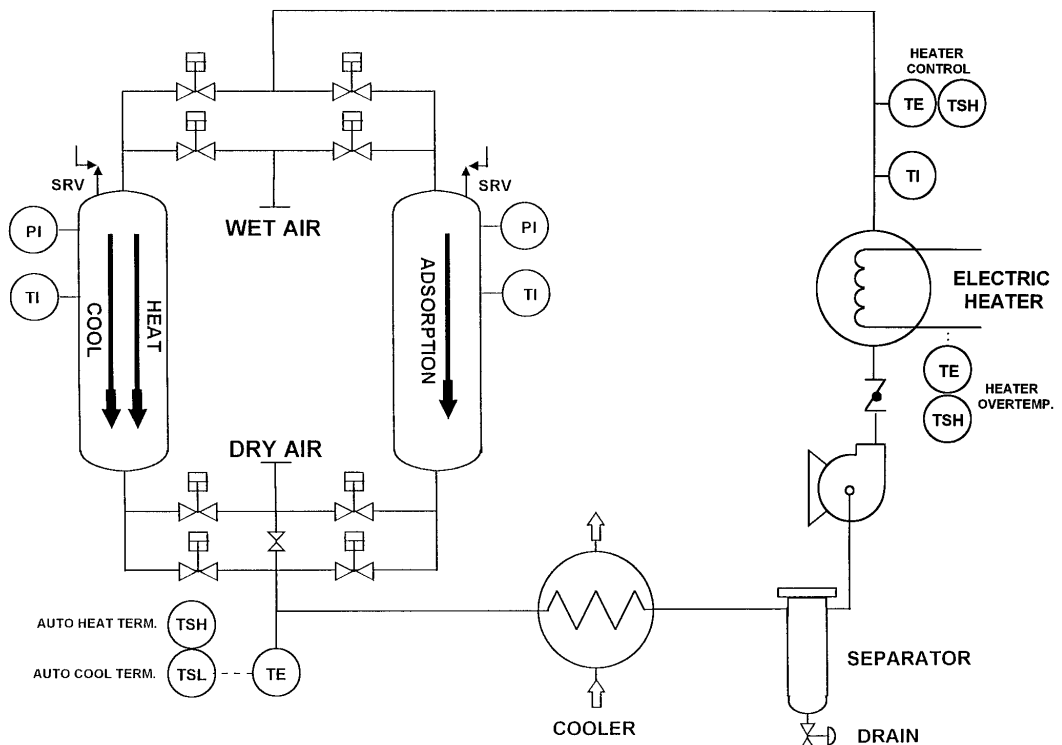



Manufacturers of quality products since 1945



GENERAL AIR
Making the world's air dryer

PSB INDUSTRIES INC.
General Air Division
1202 West 12th Street
Erie, PA 16501 USA
Phone: 814-453-3651
Toll Free: 800-829-1119
Fax: 814-454-3492
E-mail: psb@genair.net
www.psbindustries.com

Printed in U.S.A.
Form No. 309-SBG, PDF-7/02

Your Contact Is: